

Novus  
RetailSystem  
becomes  
Novus POS  
Solutions



# POS Solutions

More Space System



# Innovations on track: Novus RetailSystem becomes Novus POS Solutions.

Since the company was founded in 1949, the Novus brand stands for:

- innovative technology,
- sophisticated „German Engineering“,
- modular systems
- and high quality.

These attributes provide the basis for the modular Novus POS Solutions as the key to creating secure and attractive POS Solutions that are tailored to your needs with its versatile, flexible elements. Exactly this individuality is required for the checkout zone with its various demands.

Our space-saving flexible products are perfectly integrable into the shop's design and enhance the user friendliness at the checkout with cleverly designed details.

On daily basis our engineers work on new solutions at the Research and Development Centre at the company headquarters in Lingen, Germany. We use advanced technology in our company's own production facilities to ensure the high quality of our products.

Let our expertise benefit your business:  
We design and produce solutions for you that are tailored in every detail to your specific requirements.

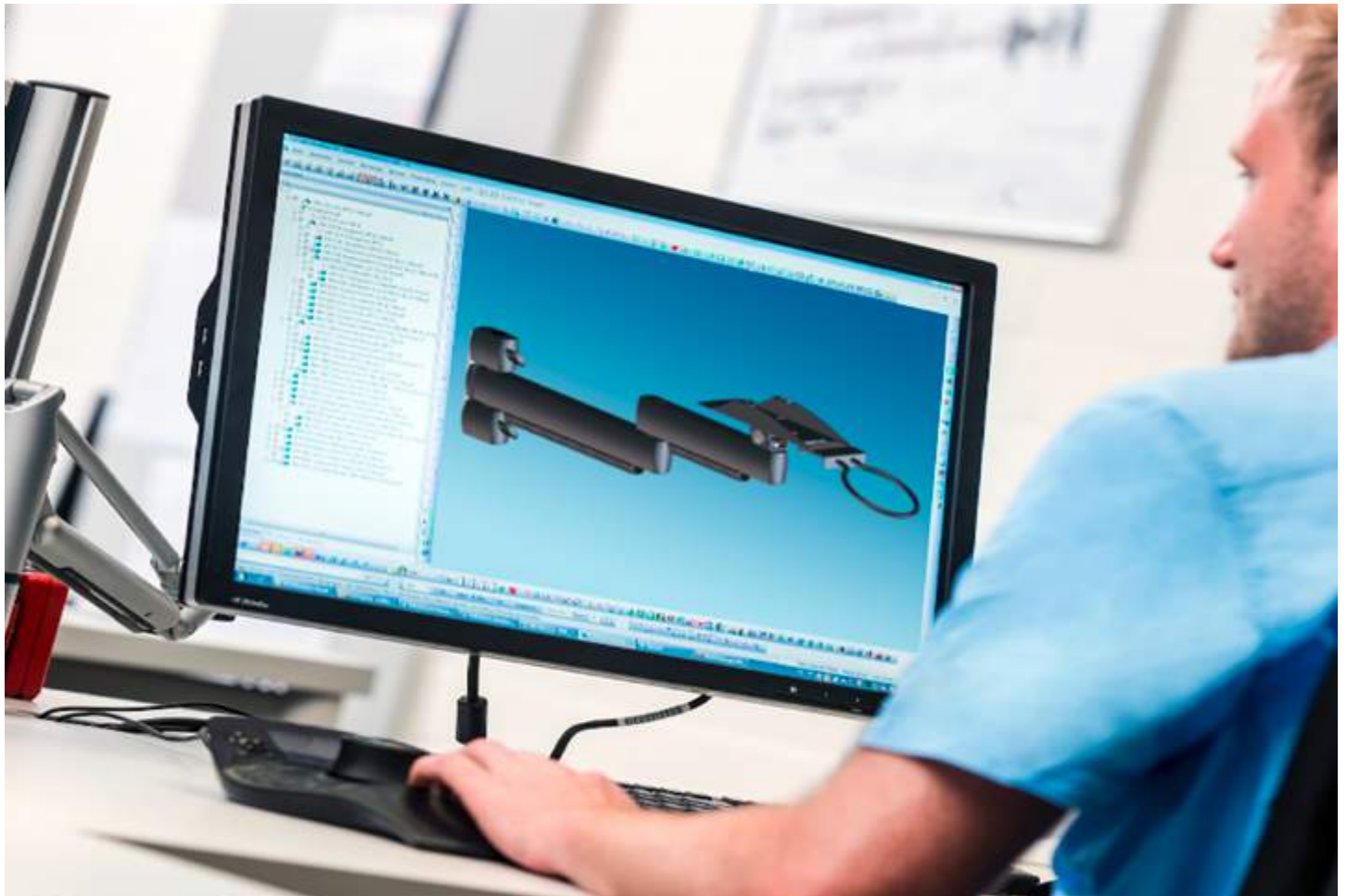



# One system – multi-purpose use



The modular system for individual solutions at your POS.





Knowing what's important to you: our POS Solutions and its components.



Screw-on and screw-through mounting for passing cables through the table.



High-quality silver- or black anodised aluminium profiles. Cables are passed through the inside of the column where they are covered by practical brush seals.



Infinitely height adjustable, the arms let you position terminals, keyboards and monitors individually.



Practical cable holders provide a secure, neatly organised cable management along the arm.

The right system for any demand.



## Mobile service perfectly integrated at the Point of Sale: Novus tablet holders.



The NOVUS TabletSafe and TabletFix expand the Novus POS Solutions with lots of practical and flexible tablet holders. Product and promotional information presented in a customer-friendly way as well as selling through mobile devices are the mark of modern customer communication and sales processes.

Whether at the point of sale or in the showroom, whether on the wall or on the counter, the versatile mounting options now provide a place for any tablet.

### NOVUS TabletSafe

High-quality metal frame with velour chrome surface and lacquered display screen

The metal frame and display screen in the anthracite version feature a colour coordinating lacquered finish

Lockable tablet holder for modern customer communication

Metal clips in the housing allow exact positioning of various tablets within the frame.



The NOVUS TabletSafe or connect plate is securely attached to the connect joint. The perfect cable management covers cables from the field of view.



Control functions remain accessible by the practical apertures. If not used, they can be closed off with cover caps.

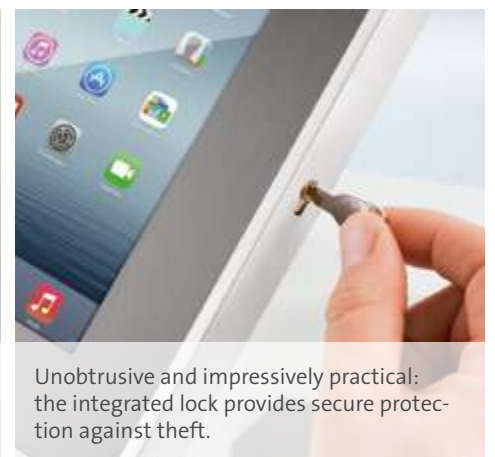

Unobtrusive and impressively practical: the integrated lock provides secure protection against theft.

## NOVUS TabletFix

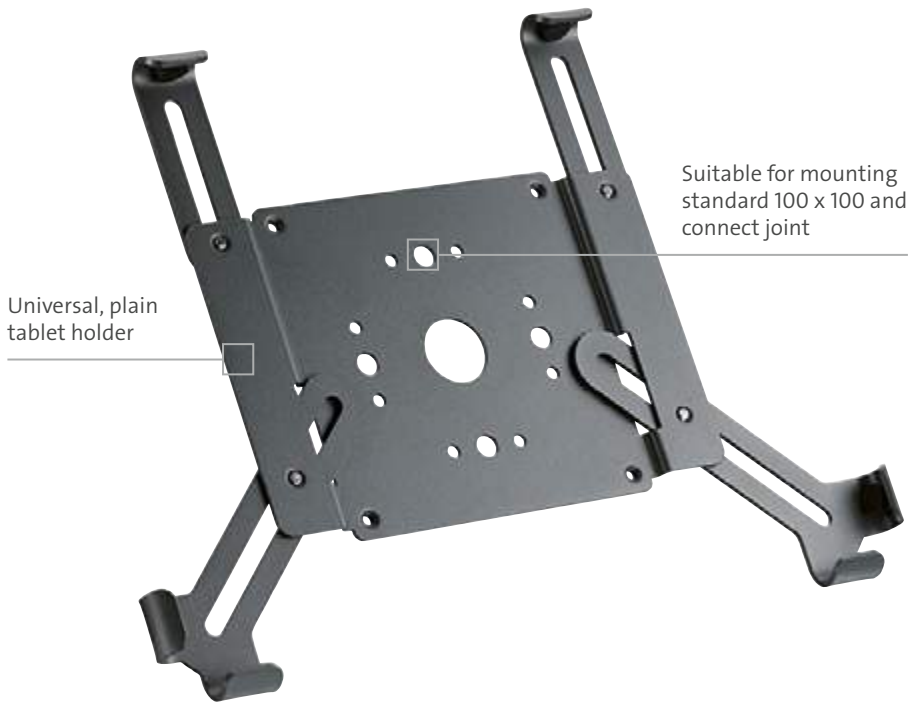

Universal, plain tablet holder

Suitable for mounting standard 100 x 100 and connect joint



High-quality powder coated metal finish



Universal tablet holder for use with various approximately 8"-10" tablets

## Everything in view.



anthracite





silver



### Novus RetailSystem base – column for RetailSystem arms

	<p><b>NOVUS RetailSystem base 200</b> Internal cable management sealed by 2 sturdy brushes; 2-in-1 mounting</p>	851+2005+000	851+2009+000	200 mm
	<p><b>NOVUS RetailSystem base 400</b> Internal cable management sealed by 2 sturdy brushes; 2-in-1 mounting</p>	851+4005+000	851+4009+000	400 mm
	<p><b>NOVUS RetailSystem base 600</b> Internal cable management sealed by 2 sturdy brushes; 2-in-1 mounting</p>	851+6005+000	851+6009+000	600 mm

### Novus RetailSystem – wall brackets

	<p><b>NOVUS TSS-wall bracket 445 WS</b> Wall bracket with 2 cable clasps and mounting material</p>	961+0505+000	961+0509+000	445 mm
	<p><b>NOVUS TSS-wall bracket 890 WS</b> Wall bracket with 2 cable clasps and mounting material</p>	961+0515+000	961+0519+000	890 mm

NEW

We can only show you a selection of our products on these pages. You will find all of our systems and solutions on the Internet at [www.novus.de/pos](http://www.novus.de/pos)

Everything in view.



anthracite



silver











Novus RetailSystem base connect – column to support RetailSystem connect plates

	<b>Novus RetailSystem base connect 100</b> Internal cable management sealed by 2 sturdy brushes; 2-in-1 mounting; tilt and turn	851+1045+000	851+1049+000	100 mm			
	<b>Novus RetailSystem base connect 200</b> Internal cable management sealed by 2 sturdy brushes; 2-in-1 mounting; tilt and turn	851+2045+000	851+2049+000	200 mm			

Novus RetailSystem – clamp bracket









 <b>NEW</b>	<b>NOVUS RetailSystem clamp HD</b> Clamp for attachment to the counter table. Suitable for the RetailSystem base columns	795+1705+014					
 <b>NEW</b>	<b>NOVUS RetailSystem clamp HD 90°</b> Clamp for attachment to the counter table. Suitable for the RetailSystem base columns	795+1705+015					





Novus RetailSystem arm – support arms for monitors

	<b>NOVUS RetailSystem arm S</b> Short, tilt and turn support arm for terminals and monitors	852+0705+000	852+0709+000		70 mm	75/100	10 kg
	<b>NOVUS RetailSystem arm M 120</b> Tilt and turn support arm for terminals and monitors	852+2005+000	852+2009+000		200 mm	75/100	10 kg
	<b>NOVUS RetailSystem arm M 200</b> Tilt and turn support arm for terminals and monitors	852+2705+000	852+2709+000		270 mm	75/100	10 kg
	<b>NOVUS RetailSystem arm M330-C</b> Support arm 330 mm for terminals and screens, additional connector for connect plate, swivelling and tiltable	852+4005+001	852+4009+001		330 mm	75/100	10 kg
	<b>NOVUS RetailSystem arm L 380</b> 2-part articulated tilt and turn support arm for terminals and monitors, additional connector for connect plate, swivelling and tiltable	853+4505+000	853+4509+000		450 mm	75/100	10 kg
	<b>NOVUS RetailSystem arm S-TV</b> Short support arm for large monitors, can be swivelled	852+0545+000	852+0549+000		50 mm	100/100 200/100 200/200	25 kg
	<b>NOVUS RetailSystem arm M-TV</b> Support arm for large monitors, can be swivelled	852+2145+000	852+2149+000		210 mm	100/100 200/100 200/200	20 kg
	<b>NOVUS RetailSystem Display holder 75</b>	852+0705+001			65 mm	75	5 kg



# The Novus RetailSystem

	anthracite	silver		
<b>Novus RetailSystem connect – support arms for RetailSystem connect plates</b>				
 <b>NOVUS RetailSystem connect M 120</b> Support arm for connect plates; tilt and turn	852+2035+000	852+2039+000	140 mm	10 kg
 <b>NOVUS RetailSystem connect M 200</b> Support arm for connect plates; tilt and turn	852+2835+000	852+2839+000	220 mm	10 kg
 <b>NOVUS RetailSystem connect L 380 D</b> 2-part support arm for connect plates; tilt and turn; downwards assembled	853+4525+000	853+4529+000	400 mm	10 kg
 <b>NOVUS RetailSystem connect L 380</b> 2-part support arm for connect plates; tilt and turn	853+4535+000	853+4539+000	400 mm	10 kg
 <b>NOVUS RetailSystem connect XL 750</b> 3-part support arm 750 mm for RetailSystem connect plates, swivelling and tiltable <b>NEW</b>	853+7505+000	853+7509+000	750 mm	5 kg
 <b>NOVUS RetailSystem connect L415 D-M right</b> 2-part support arm 160/220 mm for terminals and screens, additional connector for connect plate, swivelling and tiltable, mounting standard 75/100 <b>NEW</b>	853+4825+001	853+4829+001	160 / 220 mm	10 kg
 <b>NOVUS RetailSystem connect L415 D-M left</b> 2-part support arm 160/220 mm for terminals and screens, additional connector for connect plate, swivelling and tiltable, mounting standard 75/100 <b>NEW</b>	853+4825+002	853+4829+002	160 / 220 mm	10 kg

	black	silver / anthracite		
<b>Novus RetailSystem monitor arm Clu</b>				
 <b>NOVUS Clu I without mount</b> 1-piece gas pressure arm for flat-screens without mount, QuickRelease, mounting standard 75/100 <b>NEW</b>	990+1008+000	990+1009+000	283 mm	2-7 kg
 <b>NOVUS Clu column adapter</b> Clu column for NOVUS MY, TSS and RetailSystem base <b>NEW</b>	898+0098+000	898+0099+000		

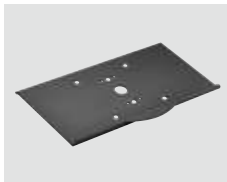

Connecting plate for keyboards



Connecting plates for EC-Cash terminals















Connecting plate for printers and scanners



Accessories

Novus RetailSystem connect plate – connecting plate for keyboards		
NOVUS Keyboard (supporting surface / B x L: 300 x 150 mm), large		851+0035+004
NOVUS Keyboard (supporting surface / B x L: 300 x 120 mm), small		851+0035+021
Novus RetailSystem connect plate – connecting plates for EC-Cash terminals		
NOVUS Ingenico ICT 250/220		851+0035+011
NOVUS Ingenico IPP 350/310		851+0035+009
NOVUS Ingenico Lane 5000	NEW	851+0035+043
NOVUS Ingenico Desk 3200 / 3500 / 5000	NEW	851+0035+046
NOVUS Ingenico IPP350 without handle		851+0035+022
NOVUS Ingenico IPP 480		851+0035+020
NOVUS Spire SPp30		851+0035+027
NOVUS Verifone VX 520 / H5000		851+0035+014
NOVUS Verifone VX 820		851+0035+012
NOVUS Verifone VX 825	NEW	851+0035+037
NOVUS Verifone MX 925	NEW	851+0035+034
NOVUS Verifone H 5000	NEW	851+0035+001
NOVUS Verifone P 400	NEW	851+0035+038
NOVUS Verifone P 400 without handle	NEW	851+0035+042
NOVUS Verifone V 200C / V 400C	NEW	851+0035+039
NOVUS Verifone V 400M	NEW	851+0035+040
NOVUS Verifone M 400	NEW	851+0035+041
NOVUS Worldline Yomani ML+XR Touch		851+0035+007
Novus RetailSystem connect plate – connecting plates for printers, scanners and standard connections		
NOVUS Aures ODP 333		851+0035+033
NOVUS Epson TM-T70		851+0035+024
NOVUS Epson TM-T20II (also for Casio UP-400)		851+0035+005
NOVUS Magelan 1100i		851+0035+003
NOVUS Orbit MS 7120		851+0035+006
NOVUS Printer I (for PartnerTECH RP 100 / RP 300 / RP 600, TM-T20II, LK-TE322)		851+0035+008
NOVUS Scanner NLS-FR 4060		851+0035+026
NOVUS Universal 160x200		851+0035+023
NOVUS Universal 183x216		851+0035+013
NOVUS Standard mounting 75/75		851+0035+029
NOVUS Standard mounting 75/100		851+0035+025
NOVUS Kronos		851+0035+030
NOVUS Sam4S Giant 100	NEW	851+0035+044
Novus RetailSystem Accessories		
NOVUS RetailSystem cable strap black, 2x velcro cable ties for cable management		851+0008+001
NOVUS Cable clips for RetailSystem, set of 5, black	NEW	795+0505+000
NOVUS RetailSystem lock silver/anthracite, Tenon lock with cable, including 2x keys		851+0009+000
NOVUS RetailSystem Baseplate X, anthracite		795+1705+001
NOVUS QuickRelease, mounting standard 75/100		795+9095+000

# The Novus RetailSystem

	anthracite*	silver**	white***			
<b>Novus TabletSafe – lockable tablet holder for Android / Apple devices (for iPad 1/2/3/4 and iPad Air/Air 2)</b>						
 <b>NOVUS RetailSystem TabletSafe iPad</b> Lockable tablet holder for Apple devices (for iPad 1/2/3/4 and iPad Air/Air 2), for portrait and landscape use, with aperture for function buttons and cable management	881+1318+000	881+1308+000	881+1301+000			
 <b>NOVUS RetailSystem TabletSafe Android</b> Lockable tablet holder for Android tablets, for portrait and landscape use, with aperture for function buttons and cable management	881+0318+000	881+0308+000	881+0301+000			
 <b>NOVUS RetailSystem TabletFix</b> Suitable for tablet sizes 8" - 10"	881+3115+000					
<b>Novus TabletSafe – stands</b>						
 <b>NOVUS DeskStand 200</b> For standing on desks, with brush seals for internal cable management	882+0205+000	882+0209+000		200 mm		
 <b>NOVUS FloorStand 1000</b> For standing on floors, with brush seals for internal cable management	882+1005+000	882+1009+000		1000 mm		
<b>Novus TabletSafe – mounts</b>						
 <b>NOVUS WallMount</b> Practical mount for connecting TabletSafe to the wall, with fixed tilting of 33 degrees	882+0035+000					
 <b>NOVUS ScreenMaster 100</b> For mounting the TabletSafe flat against the wall		940+1009+000			75/100	25 kg
 <b>NOVUS Sky WallMount</b> Wall mount with QuickRelease, load bearing capacity of up to 10 kg, mounting standard 75/100	950+0019+100				75/100	10 kg
 <b>NOVUS QuickMount</b> Wall mount with QuickRelease, load bearing capacity of up to 25 kg, mounting standard 75/100	931+0255+000				75/100	25 kg

\* TabletSafe with frame and trim in anthracite

\*\* TabletSafe with frame in silver and trim in anthracite

\*\*\* TabletSafe with frame in silver and trim in white





855-2550 | 0120 EN | Technical specifications and design are approximations, subject to change without notice.

Novus Dahle GmbH  
Novus More Space System  
Breslauer Straße 34 – 38  
49808 Lingen (Ems), Germany  
Phone +49 (0) 591 9140-0  
Fax +49 (0) 591 9140-841  
info@novus-dahle.com

[www.novus-dahle.com](http://www.novus-dahle.com)

**Toveri Pals** General Trading Company

Kuwait, Shuwaikh, Free Trade Zone,  
Block 1, Plot 35, Second Floor  
Tel: +965 5664-7575 / 76  
P.O. Box: 5711, Safat. Kuwait 13058  
E: info@toverioals.com

[www.toveripals.com](http://www.toveripals.com)

A company of the 

